

FAULHABER Whitepaper

# How to prevent step losses with Stepper Motors

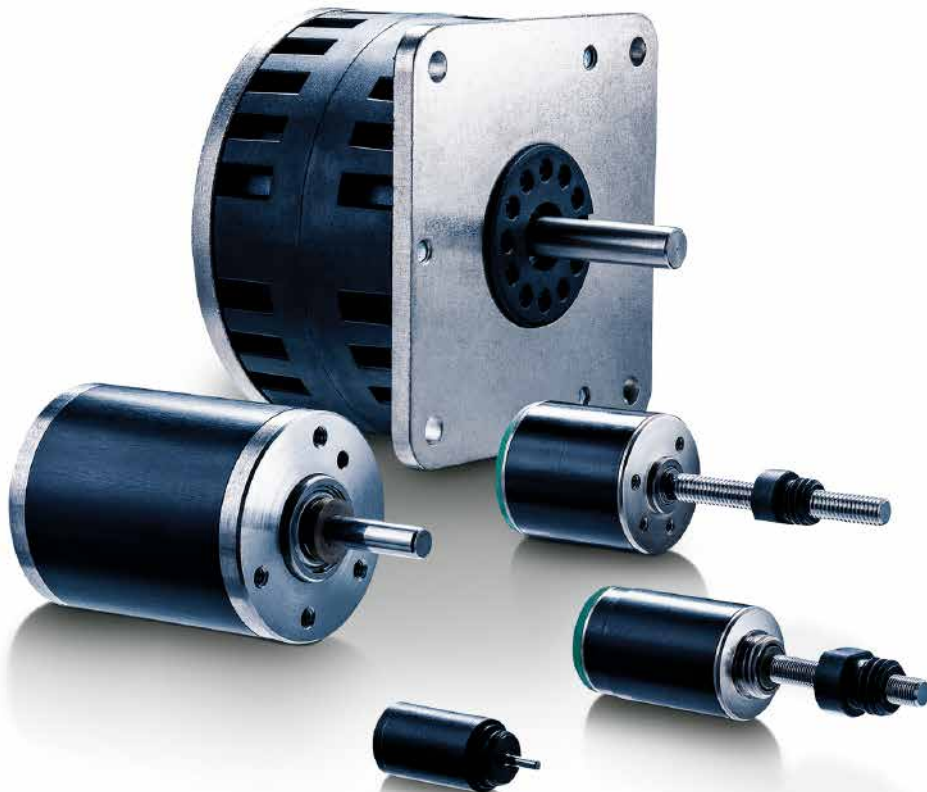

# How to prevent step losses with Stepper Motors

---

The use of stepper motors is an excellent choice. However, a key concern is step losses. Step losses can be prevented or corrected in most instances.

Stepper motors operate open loop. When a stepping motor does not operate correctly in a specific situation, the common conclusion is that either the motor or the drive electronics is faulty. The motor selection and the choice of the controller are critical. However, other factors contribute to step losses.

The following points are important to examine for the analysis of step losses or non-operation in a methodical fashion across a variety of applications.

## **Publisher / Editor:**

DR. FRITZ FAULHABER GMBH & CO. KG

Schönaich · Germany

Email: [info@faulhaber.de](mailto:info@faulhaber.de)

[www.faulhaber.com](http://www.faulhaber.com)

# A. Stepper Motor Selection

---

The first task is to select the right stepper motor for the application. For the best selection, those basic theoretical rules have to be respected:

- 1. Select the motor based on the highest torque/speed point required by the application (selection based on the worst case)**
- 2. Use a 30% design margin from the published torque vs. speed curve (pull-out curve).**
- 3. Ensure that the application cannot be stalled by external events**

It is important to remember that a stepper motor does not operate like a DC-motor. There is no working point parameterization, and the phase current does not increase when the load increases. As long as the speed vs. torque requirement of the application is within the specs of the motor, no problem will be encountered. If this requirement is out of the specs, the motor stalls (OK or NOT OK functionality). In any case, the current in the phases is not changing and adapting by itself to the situation.

The next step is to qualify the motor with practical tests and verify if step losses occur during operation. Note that by construction, a stepper motor cannot lose only one step. If speed is low, it will lose a multiple of 4 steps (8, 12, 16 ... Steps) and if the speed is high it will stop rotating. In cases that less than 4 steps are lost, the cause is in the commutation.

Since the motor is normally not equipped with a feedback device and since the motor current is not providing any assistance, this is not necessarily an easy task to find the root cause of the failure.

The next sections give some possible root causes in case the qualifications test fails.

# B. Operation mode

Depending on the type of motion profile, the analysis is different

## B1. Start-Stop operation

In this operation mode, the motor is hooked up to the load and operates at constant speed. The motor has to accelerate the load (inertia and friction) within the first step to the commanded frequency.

Fig1. Start-Stop Frequency

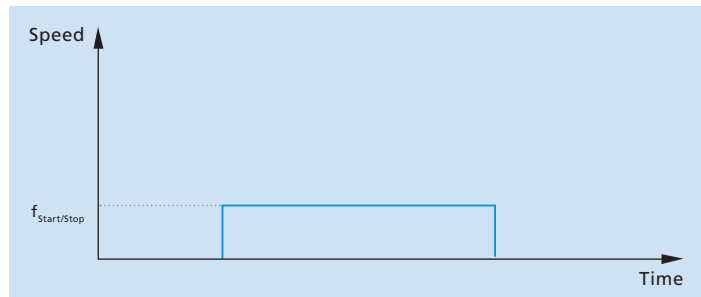

### Failure mode: Motor does not start

Reasons	Solutions
Load too high	Wrong motor, select a bigger motor
Frequency too high	Reduce
If the motor oscillates from left to right, one phase may be broken or not connected	Repair
Phase current is not appropriate	Increase phase current , at least during the first steps.

## B2. Acceleration and ramp profile (trapezoidal)

In this case, the motor is allowed to accelerate to the maximum frequency with an acceleration rate preset in the driver.

Fig2. Trapezoidal speed profile

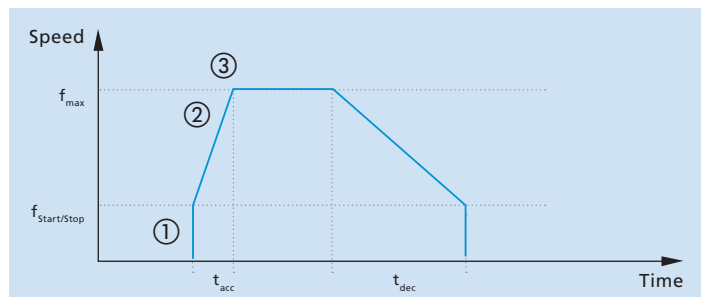

### Failure mode: Motor does not start

For reasons and solutions see B1 "Start-Stop operation".

### Failure mode: Motor does not finish the acceleration ramp.

Reasons	Solutions
Motor trapped in resonance frequency	<ul style="list-style-type: none"><li>■ Increase the acceleration to go through the resonance frequency quickly</li><li>■ Select start-stop frequency above resonance point</li><li>■ Use half-stepping or micro-stepping</li><li>■ Add a mechanical damper which can take the form of an inertial disk on rear shaft.</li></ul>
Wrong supply voltage or current setting (too low)	<ul style="list-style-type: none"><li>■ Increase voltage or current (it is allowed to set a higher value for a short period)</li><li>■ Test lower impedance motor</li><li>■ use current mode control (if voltage driver is currently used)</li></ul>
Top speed too high	<ul style="list-style-type: none"><li>■ Reduce top speed</li><li>■ Reduce the acceleration ramp, by example by defining a starting speed within the pull-in limit</li></ul>
Bad quality of the acceleration ramp from the electronics (happens with digital ramps)	<ul style="list-style-type: none"><li>■ Try with another drive</li></ul>

### Failure mode: Motor finishes acceleration but stalls when constant speed is reached.

Reasons	Solutions
The motor is operating at the limit of its ability and stalls due to too high acceleration. The equilibrium position is overshooted, causing rotor vibrations and instability.	<ul style="list-style-type: none"><li>■ Reduce jerk i.e. select a smaller acceleration rate or use two different acceleration levels, high at start, lower towards top speed.</li><li>■ Increase torque</li><li>■ Add a mechanical damper which can take the form of an inertial disk on the rear shaft. Note that this will add inertia and may not solve the problem in each case if the top speed is at the limit of the characteristics of the motor.</li><li>■ Drive the motor using micro-stepping</li></ul>

# C. External Commutation Errors

As explained earlier, a stepper motor will lose, by construction, a multiple of 4 steps (8, 12, 16 .... Steps). If the speed is high, step loss will lead to loss of synchronism. The motor stalls. If the number of missing steps is not a multiple of 4 steps, the motor is not faulty and the investigation should be focused on the commutation sequence delivered by the electronics.

The shown driver represents a type which can be commanded without any additional control element directly with a 4 bit word.

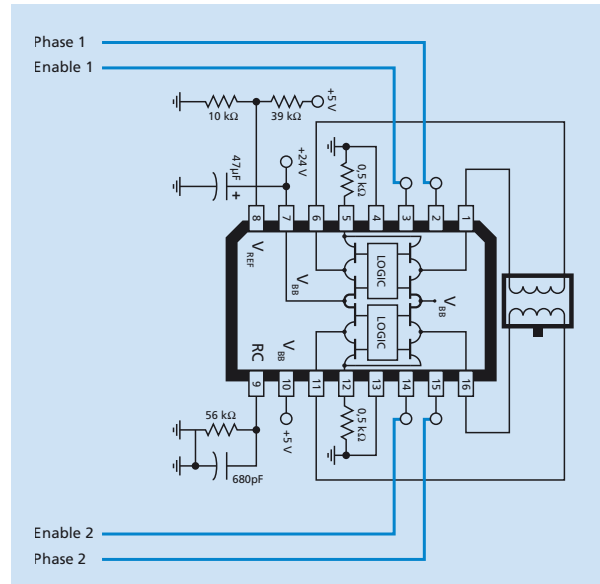

Fig4. Typical Driver

## The commutation happens as follows (one phase ON operation mode):

Phase 1	Enable 1	Phase 2	Enable 2	Current Phase A	Current Phase B
X	H	X	H	OFF	OFF
H	L	X	H	POS	OFF
X	H	H	L	OFF	POS
L	L	X	H	NEG	OFF
X	H	L	L	OFF	NEG

Table 1: One Phase ON Commutation - typical driver

This sequence is normally not the reason for any failure or step losses during normal operation when current is applied all the times to the phases. This changes when power is switched off. Power off of the controller which provides the 4 bits of the example (4 bits for Phase1, Phase2, Enable1, Enable2) will lose the counter status which is required to assure an uninterrupted stepping sequence following the above table.

At power up it is therefore not assured that the counter will find the position it had prior to power-off. If there is a difference between the counter position and the real rotor position the motor will execute uncontrolled steps. The maximum error may be 2 steps in CCW or CW direction.

### Solution

Before power-off, memorize the 4 bit word (more for more sophisticated drives) and reload it from memory for the counter initialization. Power-On with this position again before continuing the commutation.

# D. External events

---

## D1. Back driving

In some cases, the mechanism/load driven by the motor during the movement wind up and return this energy back to the motor when the currents are switched off. This mechanism may be a reduction gearhead.

As the mechanism returns this energy back, the motor shaft may be rotated backwards. If this back driving is larger than one step angle, the motor will, when the current is switched on for the next movement, not develop sufficient torque to complete the first step. It may not start or start only after 4 full-steps.

This type of failure results also in the loss of at least one commutation cycle of 4 steps.

This failure type may only occur in applications where the motor currents are considerably reduced or switched off after the movement.

### Solutions

- Program the commutation in such way that the value and polarity of the motor currents are saved before they are switched off. The saved values have to be applied when switching the motor currents on again.
- Instead of powering off, maintain a reduced stand-by current each time the motor is at stand-still.

## D2. Increase of the pay load over time

In some cases, the motor runs normally for a long period of time but lose steps after some time. In that case, it is likely that the load seen by the motor has changed. It can come from the wear of the motor bearings or from an external event.

### Solutions

- Verify the presence of an external event:
  - Has the mechanism driven by the motor changed?
- Verify the bearing wear: Use ball bearings instead of sintered sleeve bearing for extended motor life time.
- Verify if the ambient temperature has changed. Its influence on the bearing lubricant viscosity is not insignificant with the smallest motors. Use lubricants suitable for the operating range. FAULHABER steppers can be obtained with a wide range of lubricants.