

Encoders

optical Encoder, digital outputs,
2 channels, 120 lines per revolution

For combination with
Stepper Motors

Series PE22-120

		PE22-120		
Lines per revolution	N	120		
Frequency range, up to ¹⁾	f	30		kHz
Signal output, square wave		2		Channels
Supply voltage	U_{DD}	4,5 ... 5,5		V
Current consumption, typical ²⁾	I_{DD}	20		mA
Pulse width	P	180 ± 45		°e
Phase shift, channel A to B	Φ	90 ± 45		°e
Logic state width	S	90 ± 45		°e
Cycle	C	360 ± 30		°e
Signal rise/fall time, max. ($C_{LOAD} = \text{pF}$)	tr/tf	0,5 / 0,1		μs
Inertia of code disc	J	0,24		gcm ²
Operating temperature range		-20 ... +85		°C

¹⁾ Velocity (min⁻¹) = f (Hz) x 60/ N

²⁾ $U_{DD} = 5 \text{ V}$: with unloaded outputs

For combination with Motor

Dimensional drawing A	<L1 [mm]		
AM2224	38,0		
AM2224R3	40,9		

Characteristics

These incremental shaft encoders in combination with two phases stepper motors are designed for indication and control of both, shaft velocity and direction of rotation as well as for position verification.

The encoder is placed at the rear output shaft of the stepper motor and extends its overall length by 11 mm.

The supply voltage for the encoder and the stepper motors as well as the two channel output signals are interfaced through a ribbon cable with connector.

Details for the stepper motors and suitable reduction gearheads are on the corresponding data sheets.

To view our large range of accessory parts, please refer to the "Accessories" chapter.

Circuit diagram / Output signals

Output circuit

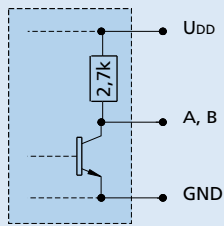

Recommendation:
Please use a latch to capture the outputs.

Output signals
with clockwise rotation as seen from the shaft end

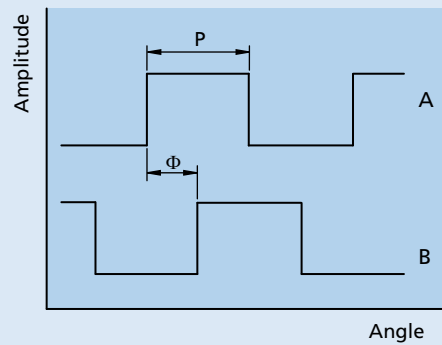

Connector information / Variants

No.	Function
1	Motor Phase A +
2	Motor Phase A -
3	Motor Phase B +
4	Motor Phase B -
5	U _{DD ENC}
6	GND
7	Channel A
8	Channel B
9	N.C.
10	N.C.

Connection Encoder and Motor

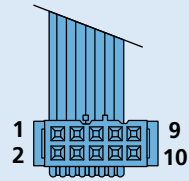

Connector
Serie 71600-010LF
PVC-ribbon cable

Full product description

- Example:
AM2224SB025016 PE22-120
AM2224R3012586 PE22-120

Dimensional drawing A

