

Motion Control Systems

V3.0, 4-Quadrant PWM
with EtherCAT interface

76 mNm

32 W

MCS 3242 ... BX4 ET

Values at 22°C and nominal voltage	MCS 3242G	024BX4 ET	
Power supply electronic	U_P	12 ... 50	V DC
Power supply motor	U_{mot}	0 ... 50	V DC
Nominal voltage for motor	U_N	24	V
No-load speed (at U_N)	n_0	4 900	min ⁻¹
Peak torque (S2 operation for max. 14s)	M_{max}	150	mNm
Torque constant	k_M	41,4	mNm/A
PWM switching frequency	f_{PWM}	100	kHz
Efficiency electronic	η	95	%
Standby current for electronic (@ $U_P=24V$)	I_{el}	0,06	A
Speed range (up to 30V)		1 ... 6 200	min ⁻¹
Shaft bearings	ball bearings, preloaded		
Shaft load max.:			
– with shaft diameter	5		mm
– radial at 3 000 min ⁻¹ (5 mm from mounting flange)	50		N
– axial at 3 000 min ⁻¹ (push / pull)	5		N
– axial at standstill (push / pull)	50		N
Shaft play:			
– radial	≤ 0,015		mm
– axial	= 0		mm
Operating temperature range	-40 ... +85		°C
Housing material	aluminium, stainless steel		
Protection class, with option V ring	IP54		
Mass	356		g

Rated values for continuous operation			
Rated torque	M_N	76	mNm
Rated current (thermal limit)	I_N	1,82	A
Rated speed	n_N	2 800	min ⁻¹

Interface / range of functions	... ET
Configuration from Motion Manager 6.0	RS232
Fieldbus	EtherCAT
Operating modes	PP, PV, PT, CSP, CSV, CST and homing acc. to IEC 61800-7-201 or IEC 61800-7-301 as well as position-, speed- and torque control via analog setpoint or voltage controller
Speed range	see motor diagram
Application programs	Max. 8 application programs (BASIC), one of which is an autostart function
Additional functions	Touch-probe input, connection of a second incremental encoder, control of a holding brake
Indicator	LEDs for displaying the operating state Trace as recorder (scope function) or logger

Note:

The display shows the range of possible operation points of the drives at a given ambient temperature of 22°C.

The diagram indicates the recommended speed in relation to the available torque at the output shaft.

It includes the assembly on a plastic- as well as on a metal flange (assembly method: IM B 5).

The nominal voltage linear slope describes the maximal achievable operating points at nominal voltage. Any points of operation above this linear slope will require a supply voltage $U_{mot} > U_N$.

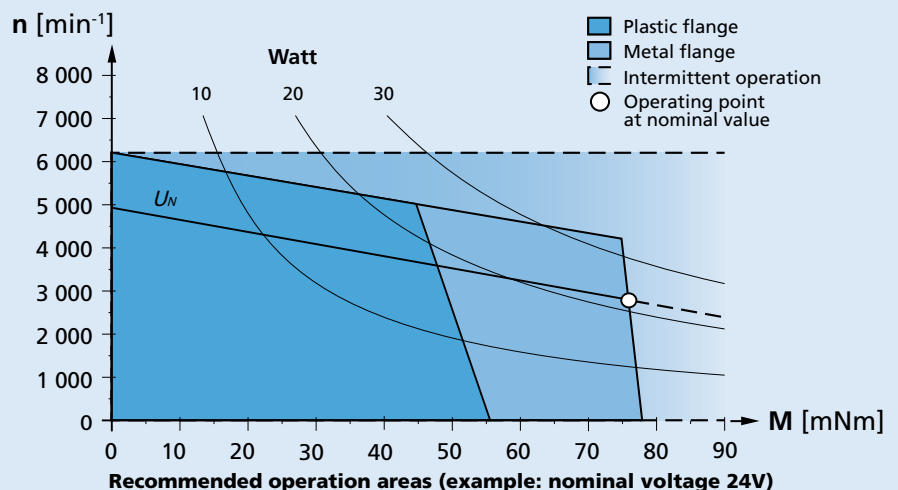

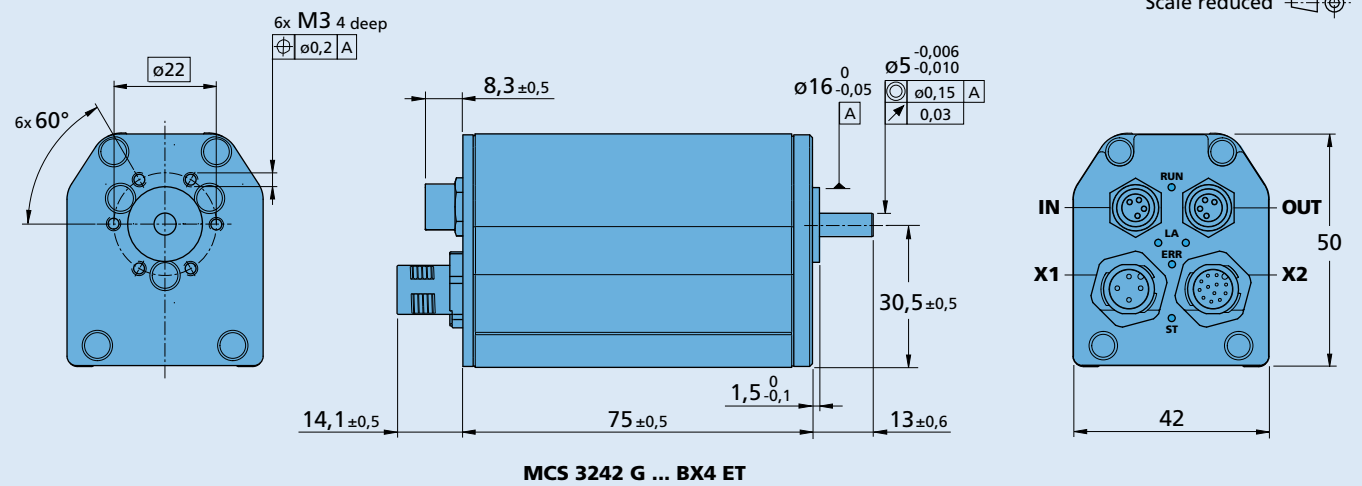
Dimensional drawing

Option, cable and connection information

 Example product designation: **MCS3242G0248X4ET-5453**

Option	Type	Description	Connection			
			Name	Function	Inputs-outputs	Description
5452	Shaft seal	For use with oil emulsive substances	X1	Motor and electronic power supply		
5453	Shaft seal	IP54 according to IEC 60529	X2	Inputs-outputs	DigIn1, DigIn2, DigIn3 DigOut1, DigOut2 AnIn1, AnIn2 U _{out} / GND	TTL or. PLC level max. 0,7A continuous current ± 10V against AGND 5V
5657	Motor flange seal	IP54 according to IEC 60529	IN	Fieldbus		EtherCAT IN
			OUT	Fieldbus		EtherCAT OUT
			Note: For details on the connection assignment, see device manual for the MCS.			

Product combination

Precision Gearheads / Lead Screws	Encoders	Drive Electronics	Cables / Accessories
32GPT 32/3 32/3R 42GPT		Integrated	To view our large range of accessory parts, please refer to the "Accessories" chapter.