

Motion Controllers

V2.5, 4-Quadrant PWM
with RS232 or CAN interface

MCLM 3002 S

Values at 22°C		MCLM 3002 S	
Power supply electronic	U_B/U_{EL}	8 ... 30	V DC
Power supply motor ¹⁾	$-/U_B$	0 ... 30	V DC
PWM switching frequency	f_{PWM}	78,12	kHz
Efficiency electronic	η	95	%
Max. continuous output current	I_{cont}	2	A
Max. peak output current ²⁾	I_{max}	3	A
Standby current for electronic (at $U_B=24V$)	I_{el}	0,04	A
Operating temperature range		-25 ... +85	°C
Housing material		Hotmelt	
Mass		16	g

¹⁾ Only available for option 3085 (separate power supply)

²⁾ S2 mode for max. 5s

Interfaces	MCLM 3002 S RS	MCLM 3002 S CO
Interface	RS232	CAN (CiA)
Protocol	FAULHABER - ASCII	CANopen

Basic features

- Operation of brushless linear DC-Servomotors
- Supported sensor systems: analog Hall sensors
- Positioning resolution when using analog Hall sensors as position encoder: 3000 increments per revolution
- Max. 3 digital inputs, max. 1 digital output, 1 analog input. Not all I/Os available depending on wiring
- Setpoint specification via fieldbus, quadrature signal, pulse and direction or analog inputs
- Optional stand-alone operation via application programs with the RS232 interface version

Range of functions

Operating modes (RS Versions)	Position, speed and torque control with setpoint specification via interface or analog. Position control with Gearing Mode or stepper motor operation. Operation as Servo Amplifier in voltage controller mode
Operating modes (CO Version)	Profile Position Mode (PP), Profile Velocity Mode (PV), Homing Mode. Cyclic Synchronous Position Mode (CSP) acc. to IEC 61800-7-201 or IEC 61800-7-301.
Velocity range	2 mm/s ... 10 000 mm/s
Application programs	Available in versions with RS232 interface
Additional functions	Overload protection for electronics and motor, self-protection from overheating, over-voltage protection in generator mode.
Indicator	Trace as logger
Motor types	Brushless Linear DC-Servomotors with analog Hall sensors

Dimensional drawing

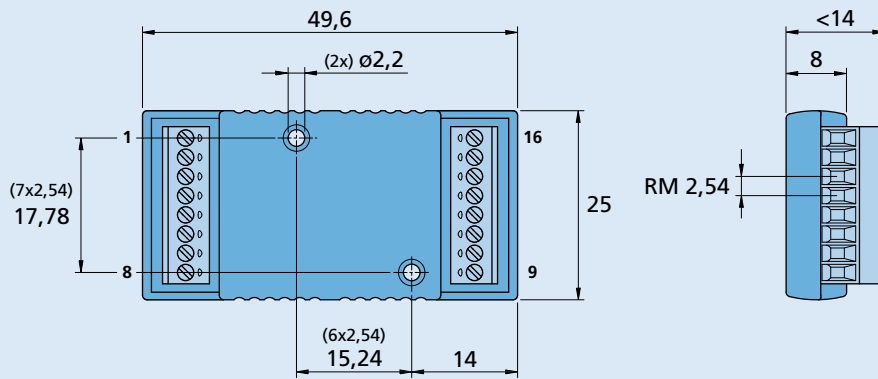

MCLM 3002 S

Options and connection information

Example product designation: **MCLM 3002 S RS 3085**

Option	Type	Description	Connection	
			No. Function	No. Function
3085	Supply	Separate power supply for motor and electronics	1 TxD / CAN_H	9 Sensor A
			2 RxD / CAN_L	10 Sensor B
			3 AGND	11 Sensor C
			4 Fault	12 U_{cc}
			5 AnIn	13 SGND
			6 U_b	14 Motor A
			7 GND	15 Motor B
			8 3. In	16 Motor C

Note: For details on the connection assignment, see device manual MC.

Product combination

Linear DC-Servomotors	Cables / Accessories
LM 0830 ... 01 LM 1247 ... 11 LM 1483 ... 11	To view our large range of accessory parts, please refer to the „Accessories“ chapter.