

NEW

Encoders

magnetic Encoder, digital outputs, 3 channels,
256 - 4096 lines per revolution, Line Driver

For combination with
DC-Micromotors

Series IEH3-4096L

		IEH3-256L	IEH3-512L	IEH3-1024L	IEH3-2048L	IEH3-4096L	
Lines per revolution	<i>N</i>	256	512	1 024	2 048	4 096	
Frequency range, up to ¹⁾	<i>f</i>	80	160	320	640	875	kHz
Signal output, square wave		2+1 Index and complementary outputs					Channels
Supply voltage	<i>U_{DD}</i>	4,5 ... 5,5					V
Current consumption, typical ²⁾	<i>I_{DD}</i>	typ. 25, max. 43					mA
Index Pulse width ³⁾	<i>P₀</i>	90 ± 45		90 ± 65	90 ± 75		°e
Phase shift, channel A to B ³⁾	<i>Φ</i>	90 ± 45		90 ± 65	90 ± 75		°e
Inertia of sensor magnet	<i>J</i>	0,11					gcm ²
Operating temperature range		-40 ... +100					°C
Accuracy, typ.		0,8					°m
Repeatability, typ.		0,07					°m
Hysteresis		0,35					°m
Edge spacing, min.		225					ns
Mass, typ.		5					g

¹⁾ Velocity (min⁻¹) = *f* (Hz) x 60/*N*

²⁾ *U_{DD}* = 5 V: with unloaded outputs

³⁾ At 5 000 min⁻¹

Note: The output signals are TIA-422 compatible.
Examples of Line Driver Receivers: ST26C32AB (STM), AM26C32 (TI).

For combination with Motor

Dimensional drawing A	<L1 [mm]		
1336 ... CXR - 123	47,5		
Dimensional drawing B			
1516 ... SR	18,2		
1524 ... SR	26,2		
1717 ... SR	19,4		
1724 ... SR	26,4		
2224 ... SR	26,6		
2232 ... SR	34,6		
Dimensional drawing C			
1727 ... CXR - 123	38,2		
1741 ... CXR - 123	52,2		

Characteristics

These incremental encoders with 3 output channels, in combination with the FAULHABER Motors, are used for the indication and control of both shaft velocity and direction of rotation as well as for positioning.

The encoder is integrated in the DC-Micromotors SR-Series and extends the overall length by only 1,4 mm with 3 output channels and Line Driver.

A segmented magnetic disc provides a magnetic field which is detected and further processed by an angle sensor. The output signals of both channels consist of a square wave signal with 90° phase shift and up to 4096 impulses and an index impulse per motor revolution.

The Line Driver amplifies the encoder signal which means that long cables can be used without signal degradation.

Differential signal outputs must be decoded by the appropriate receiver module. In addition, a suitable line termination resistance (100 ohm) is possibly useful.

The supply voltage for the encoder and the DC-Micromotor as well as the two channel output signals are interfaced through a ribbon cable with connector.

Details for the DC-Micromotors and suitable reduction gearheads are on separate catalogue pages.

To view our large range of accessory parts, please refer to the "Accessories" chapter.

Circuit diagram / Output signals

Output circuit

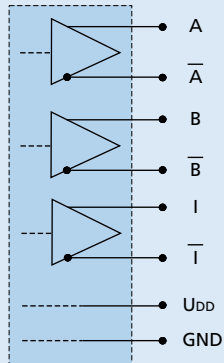

Output signals

with clockwise rotation as seen from the shaft end

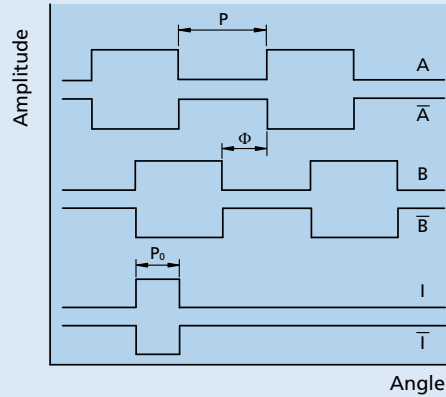

Connector information / Variants

No.	Function
1	Motor - *
2	U _{DD}
3	GND
4	Motor + *
5	Channel A
6	Channel \bar{A}
7	Channel B
8	Channel \bar{B}
9	Channel I
10	Channel \bar{I}

* Note: DC-Micromotors series CXR have separate motor leads.

Connection Encoder

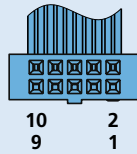

Cable
PVC-ribbon cable
10-AWG 28, 0,09 mm²

Connector
Pancon DIN-41651,
050-010-435A,
recommended connector
Berg 71918-010.

Full product description

Example:
1516T006SR IEH3-4096L

Dimensional drawing A

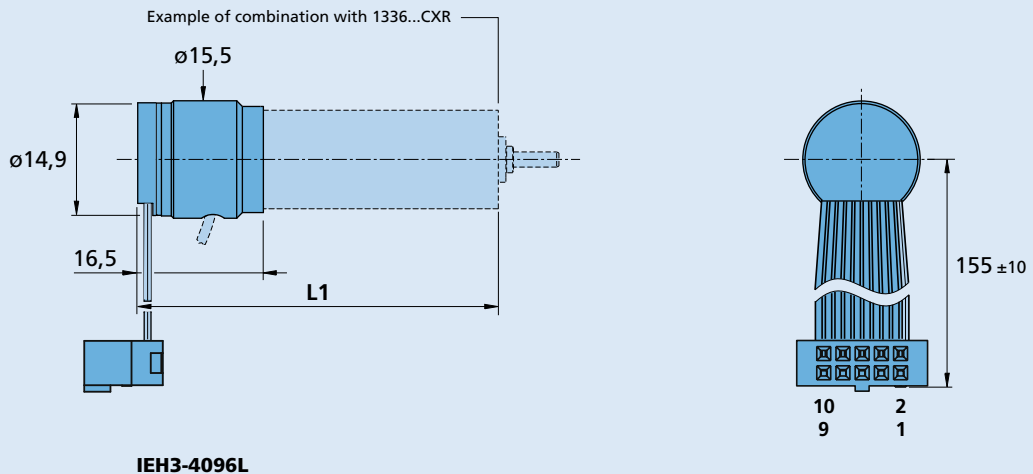

IEH3-4096L

Dimensional drawing B

Example of combination with 1724...SR

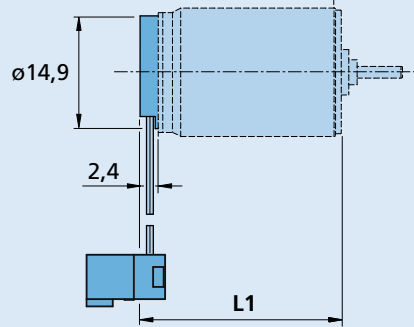

IEH3-4096L

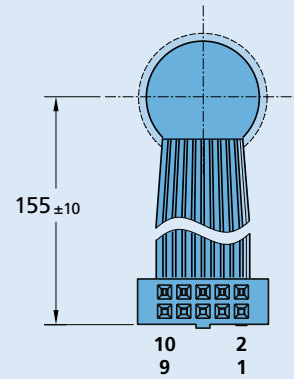

Dimensional drawing C

Example of combination with 1727...CXR

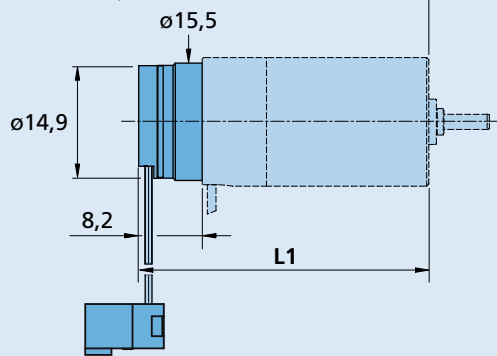

IEH3-4096L

