

Brushless DC-Servomotors

2 Pole Technology

217 mNm
282 W

Series 4490 ... BS

Values at 22°C and nominal voltage	4490 H	024 BS	036 BS	048 BS	
1 Nominal voltage	U_N	24	36	48	V
2 Terminal resistance, phase-phase	R	0,66	1,31	2,1	Ω
3 Efficiency, max.	η_{max}	87	87	88	%
4 No-load speed	n_0	5 500	5 900	6 100	min ⁻¹
5 No-load current, typ. (with shaft \varnothing 6 mm)	I_0	0,161	0,119	0,094	A
6 Stall torque	M_H	1 523	1 612	1 724	mNm
7 Friction torque, static	C_0	3,86	3,86	3,86	mNm
8 Friction torque, dynamic	C_V	$5,2 \cdot 10^{-4}$	$5,2 \cdot 10^{-4}$	$5,2 \cdot 10^{-4}$	mNm/min ⁻¹
9 Speed constant	k_n	227	162	126	min ⁻¹ /V
10 Back-EMF constant	k_E	4,4	6,16	7,92	mV/min ⁻¹
11 Torque constant	k_M	42	58,8	75,6	mNm/A
12 Current constant	k_I	0,024	0,017	0,013	A/mNm
13 Slope of n-M curve	$\Delta n / \Delta M$	3,6	3,6	3,5	min ⁻¹ /mNm
14 Terminal inductance, phase-phase	L	219	430	711	μ H
15 Mechanical time constant	τ_m	4,9	4,9	4,8	ms
16 Rotor inertia	J	130	130	130	gcm ²
17 Angular acceleration	α_{max}	117	124	133	$\cdot 10^3$ rad/s ²
18 Thermal resistance	R_{th1} / R_{th2}	0,96 / 3,9			K/W
19 Thermal time constant	τ_{w1} / τ_{w2}	23 / 1 222			s
20 Operating temperature range:					
– motor		-30 ... +125			°C
– winding, max. permissible		+125			°C
21 Shaft bearings		ball bearings, preloaded			
22 Shaft load max.:					
– with shaft diameter		6			mm
– radial at 3 000 min ⁻¹ (5 mm from mounting flange)		113			N
– axial at 3 000 min ⁻¹ (push only)		45			N
– axial at standstill (push only)		135			N
23 Shaft play:					
– radial	\leq	0,015			mm
– axial	$=$	0			mm
24 Housing material		aluminium, black anodized			
25 Mass		742			g
26 Direction of rotation		electronically reversible			
27 Speed up to	n_{max}	16 000			min ⁻¹
28 Number of pole pairs		1			
29 Hall sensors		digital			
30 Magnet material		NdFeB			
Rated values for continuous operation					
31 Rated torque	M_N	183	181	183	mNm
32 Rated current (thermal limit)	I_N	5,1	3,59	2,83	A
33 Rated speed	n_N	4 940	5 380	5 650	min ⁻¹

Note: Rated values are calculated with nominal voltage and at a 22°C ambient temperature. The R_{th2} value has been reduced by 25%.

Note:

The diagram indicates the recommended speed in relation to the available torque at the output shaft for a given ambient temperature of 22°C.

The diagram shows the motor in a completely insulated as well as thermally coupled condition (R_{th2} 50% reduced).

The nominal voltage (U_N) curve shows the operating point at nominal voltage in the insulated and thermally coupled condition. Any points of operation above the curve at nominal voltage will require a higher operating voltage. Any points below the nominal voltage curve will require less voltage.

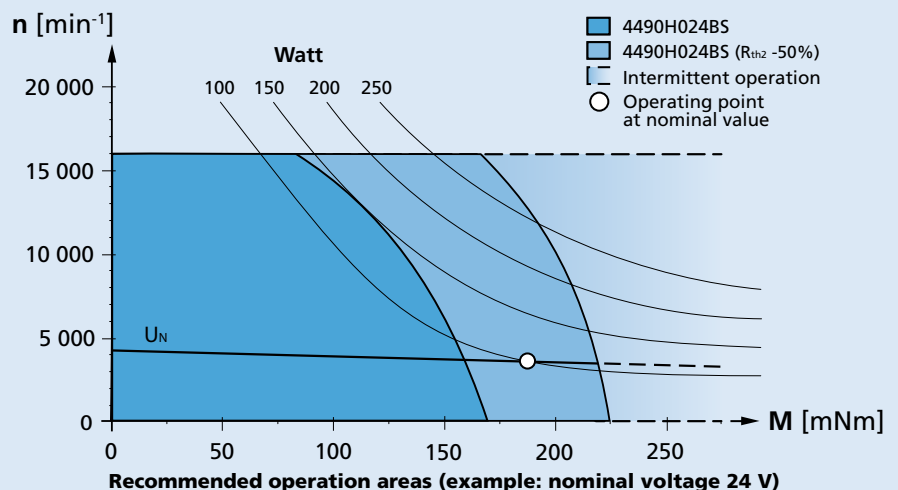

Dimensional drawing

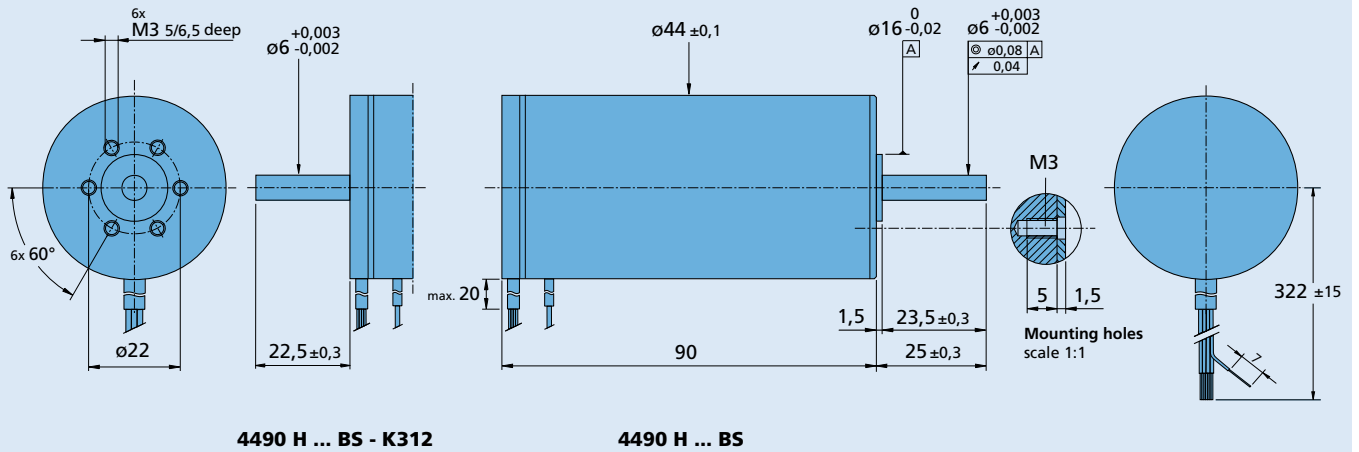
 Scale reduced 

Option, cable and connection information

 Example product designation: **4490H024BS-K1155**

Option	Type	Description	Connection	
			Function	Colour
K1155	Controller combination	Analog Hall sensors for combination with Motion Controller MCBL	Phase C	yellow
K1026	Sensorless	Motor without Hall sensors	Phase B	orange
K1838	Encoder combination	Motor with rear end shaft for combination with Encoder IE3	Phase A	brown
K312	Encoder combination	Motor with rear end shaft for combination with Encoder HEDS/HEDL/HEDM	GND	black
K3051	Encoder combination	Motor with rear end shaft for combination with Encoder AES	U _{DD} (+5V)	red
K179	Bearing lubrication	For vacuum of 10 ⁻⁵ Pa @ 22°C	Hall sensor C	grey
			Hall sensor B	blue
			Hall sensor A	green
			Standard cable	
			Single wires, material PTFE	
			AWG 16: Phase A/B/C	
			AWG 26: Hall A/B/C, U _{DD} , GND	

Product combination

Precision Gearheads / Lead Screws	Encoders	Drive Electronics	Cables / Accessories
38A 44/1	HEDS 5500 IE3-1024 IE3-1024 L HEDL 5540 AES-4096	SC 5004 P SC 5008 S MCBL 3006 S MC 5010 S	MBZ To view our large range of accessory parts, please refer to the "Accessories" chapter.