

**NEW**

# Brushless DC-Servomotors

with integrated Speed Controller,  
external rotor technology, with housing

**92 mNm**  
**60 W**

## 4221 ... BXT H SC

Values at 22°C and nominal voltage	4221 G	024 BXT H SC	
Power supply electronic	$U_P$	6,5 ... 30	V DC
Power supply motor	$U_{mot}$	6,5 ... 30	V DC
Nominal voltage for motor	$U_N$	24	V
No-load speed (at $U_N$ )	$n_0$	6 200	min <sup>-1</sup>
Peak torque (S2 operation for max. 5s)	$M_{max}$	184	mNm
Torque constant	$k_M$	28,8	mNm/A
PWM switching frequency	$f_{PWM}$	24	kHz
Efficiency electronic	$\eta$	95	%
Standby current for electronic (at $U_N$ )	$I_{el}$	0,02	A
Speed range (up to 30V)		200 ... 7 800	min <sup>-1</sup>
Shaft bearings	ball bearings, preloaded		
Shaft load max.:			
– with shaft diameter	5		mm
– radial at 3 000 min <sup>-1</sup> (3 mm from mounting flange)	25		N
– axial at 3 000 min <sup>-1</sup> (push / pull)	4		N
– axial at standstill (push / pull)	50		N
Shaft play:			
– radial	≤ 0,015		mm
– axial	= 0		mm
Operating temperature range	-40 ... +100		°C
Housing material	stainless steel		
Mass	142		g

### Rated values for continuous operation

Rated torque	$M_N$	92	mNm
Rated current (thermal limit)	$I_N$	2,58	A
Rated speed	$n_N$	5 000	min <sup>-1</sup>

### Interface / range of functions

	... SC
Configuration from Motion Manager 6.6	via USB Programming Adapter
Operating modes	Integrated speed control via PI controller and external set value specification; commutation via digital Hall sensors. Can optionally be operated in voltage controller mode or fixed speed mode.
Speed range	Digital Hall = from 200 min <sup>-1</sup>
Additional functions	Integrated current limiting to protect against thermal overload. Intermittent operation (S2) with up to double the continuous current. Separate voltage supply for motor and electronics. Direction of rotation changeover through separate switching input; reading of speed signal via frequency output.

#### Note:

The display shows the range of possible operation points of the drives at a given ambient temperature of 22°C.

The diagram indicates the recommended speed in relation to the available torque at the output shaft.

It includes the assembly on a plastic- as well as on a metal flange (assembly method: IM B 5).

The nominal voltage linear slope describes the maximal achievable operating points at nominal voltage. Any points of operation above this linear slope will require a supply voltage  $U_{mot} > U_N$ .

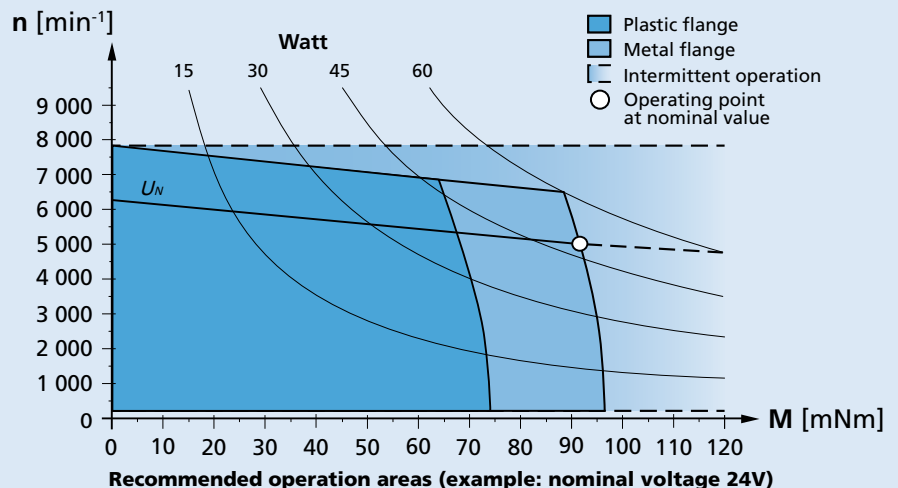

### Dimensional drawing

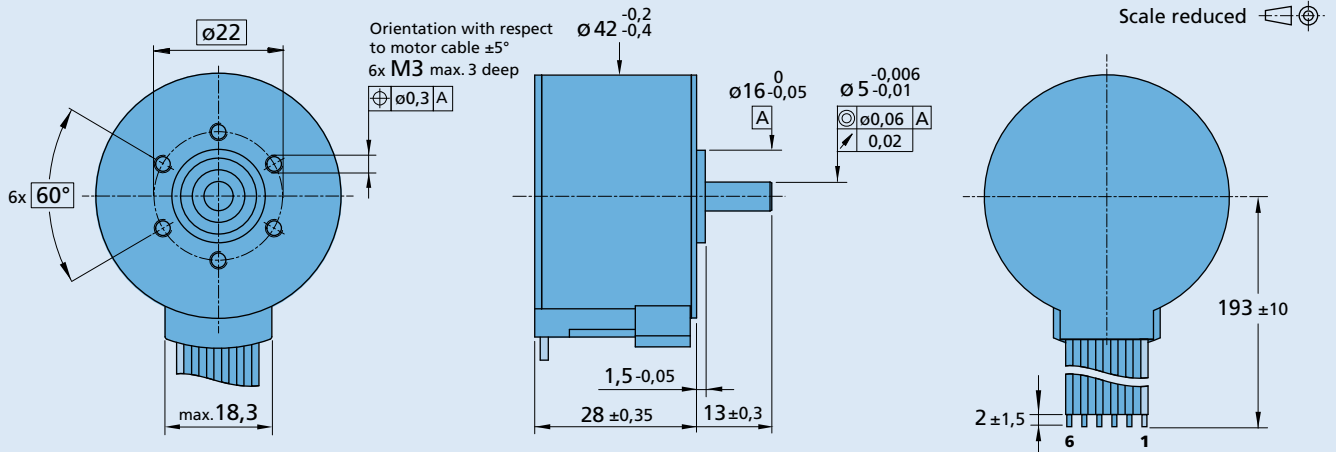

4221 G ... BXT H SC

### Option, cable and connection information

Example product designation: **4221G024BXT HSC**

Option	Type	Description	Connection			
			Name	Function	Inputs-outputs	Description
3809	Connector	AWG 24 / PVC ribbon cable with connector MOLEX Microfit 3.0, 43025-0600, recommended mating connector 43020-0600	1	$U_p$	power supply electronic	6,5 ... 30 V DC
			2	$U_{mot}$	power supply motor	6,5 ... 30 V DC
			3	GND	ground	
			4	$U_{soll}$	input voltage	$U_{in} = 0 \dots 10 \text{ V} \mid > 10 \text{ V} \dots U_p$ » set speed value not defined
					input resistance	$R_{in} \geq 8,9 \text{ k}\Omega$
					set speed value	per 1 V, 1 000 $\text{min}^{-1}$
						$U_{in} < 0,15 \text{ V}$ » motor stops
						$U_{in} > 0,3 \text{ V}$ » motor starts
			5	DIR	direction of rotation	to ground or $U < 0,5 \text{ V}$ » counterclockwise
					input resistance	$U > 3 \text{ V}$ » clockwise
						$R_{in} \geq 10 \text{ k}\Omega$
			6	FG	frequency output	max. $U_p$ ; $I_{max} = 15 \text{ mA}$ ; open collector with 22 k $\Omega$ pull-up resistor 21 lines per revolution
			<b>Standard cable</b>			
			PVC ribbon cable 6 x AWG 24, 2,54 mm			
			<b>Note:</b> For details on the connection assignment, see device manual for the SCS.			

### Product combination

Precision Gearheads / Lead Screws	Encoders	Drive Electronics	Cables / Accessories
38/1 38/1 S 38/2 38/2 S 42GPT		Integrated	To view our large range of accessory parts, please refer to the "Accessories" chapter.