

Brushless DC-Servomotors

with integrated Speed Controller
4 Pole Technology

17,5 mNm
10,5 W

2232 ... BX4 SC

Values at 22°C and nominal voltage	2232 S	012 BX4 SC	024 BX4 SC	
Power supply electronic	U_P	5 ... 28	5 ... 28	V DC
Power supply motor	U_{mot}	6 ... 28	6 ... 28	V DC
Nominal voltage for motor	U_N	12	24	V
No-load speed (at U_N)	n_0	7 000	7 100	min ⁻¹
Peak torque (S2 operation for max. 1s/2s)	M_{max}	34	35	mNm
Torque constant	k_M	16,5	31,4	mNm/A
PWM switching frequency	f_{PWM}	96	96	kHz
Efficiency electronic	η	95	95	%
Standby current for electronic (@ U_N)	I_{el}	0,02	0,02	A
Speed range (up to 24V / 28V)		400 ... 14 000	400 ... 8 500	min ⁻¹
Shaft bearings		ball bearings, preloaded		
Shaft load max.:				
– with shaft diameter	3			mm
– radial at 3 000 min ⁻¹ (3 mm from mounting flange)	20			N
– axial at 3 000 min ⁻¹ (push / pull)	2			N
– axial at standstill (push / pull)	20			N
Shaft play:				
– radial	≤ 0,015			mm
– axial	= 0			mm
Operating temperature range		-40 ... +85		°C
Housing material		stainless steel		
Mass		77		g

Rated values for continuous operation

Rated torque	M_N	17	17,5	mNm
Rated current (thermal limit)	I_N	1	0,57	A
Rated speed	n_N	4 100	4 700	min ⁻¹

Interface / range of functions

	... SC
Configuration from Motion Manager 5.0	via USB Programming Adapter
Operating modes	Integrated speed control via PI controller and external set value specification; commutation via digital Hall sensors (or optionally via analog Hall sensors). Can optionally be operated in voltage controller mode or fixed speed mode.
Speed range	Digital Hall = from 400 min ⁻¹ , analog Hall = from 50 min ⁻¹
Additional functions	Integrated current limiting to protect against thermal overload. Intermittent operation (S2) with up to double the continuous current. Separate voltage supply for motor and electronics. Direction of rotation changeover through separate switching input; reading of speed signal via frequency output.

Note:

The display shows the range of possible operation points of the drives at a given ambient temperature of 22°C.

The diagram indicates the recommended speed in relation to the available torque at the output shaft.

It includes the assembly on a plastic- as well as on a metal flange (assembly method: IM B 5).

The nominal voltage linear slope describes the maximal achievable operating points at nominal voltage. Any points of operation above this linear slope will require a supply voltage $U_{mot} > U_N$.

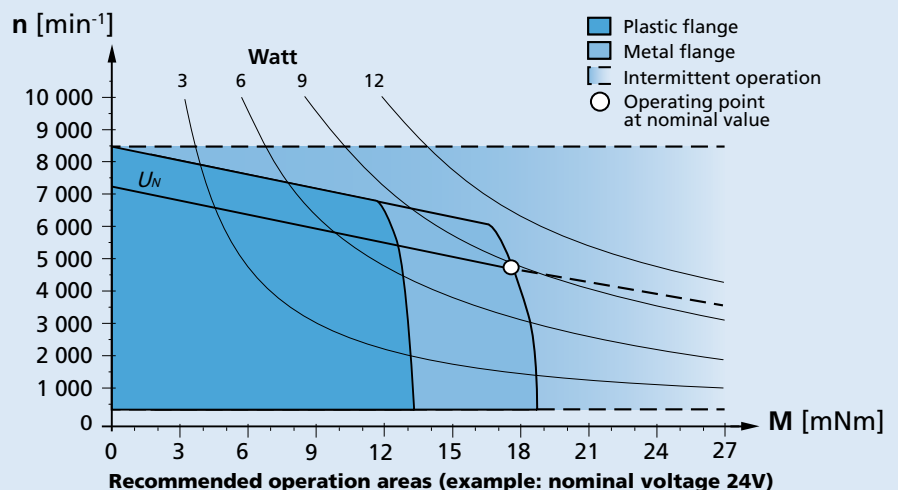

Dimensional drawing

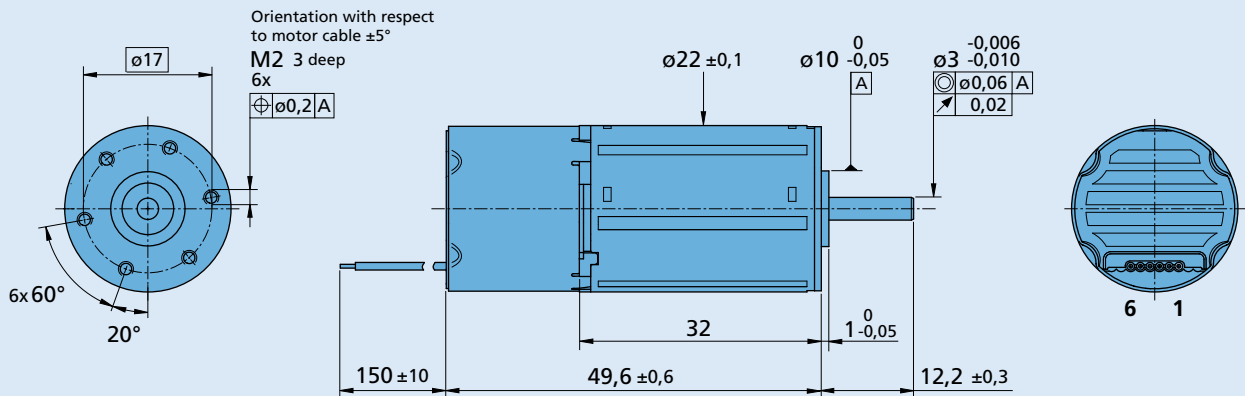

2232 S ... BX4 SC

Option, cable and connection information

Example product designation: **2232S024BX4SC-3692**

Option	Type	Description	Connection			
			Name	Function	Inputs-outputs	Description
3809	Connector	AWG 26 / PVC ribbon cable with connector MOLEX Microfit 3.0, 43025-0600, recommended mating connector 43020-0600	1	U_P	power supply electronic	5 ... 28 V DC
			2	U_{mot}	power supply motor	6 ... 28 V DC
			3	GND	ground	
3692	Sensors	Analog Hall Sensors	4	U_{soll}	input voltage	$U_{in} = 0 \dots 10 \text{ V} \mid > 10 \text{ V} \dots U_P$ » set speed value not defined
					input resistance	$R_{in} \geq 8,9 \text{ k}\Omega$
					set speed value	per 1 V, 1 000 min^{-1}
						$U_{in} < 0,15 \text{ V}$ » motor stops
						$U_{in} > 0,3 \text{ V}$ » motor starts
			5	DIR	direction of rotation	to ground or $U < 0,5 \text{ V}$ » counterclockwise
					input resistance	$U > 3 \text{ V}$ » clockwise
						$R_{in} \geq 10 \text{ k}\Omega$
			6	FG	frequency output	max. U_P ; $I_{max} = 15 \text{ mA}$; open collector with 22 k Ω pull-up resistor
						6 lines per revolution
			Standard cable			
			PVC ribbon cable 6 x AWG 26, 1,27 mm			
			Note: For details on the connection assignment, see device manual for the SCS.			

Product combination

Precision Gearheads / Lead Screws	Encoders	Drive Electronics	Cables / Accessories
22GPT 22/7 26A 22L ... ML 22L ... PB 22L ... SB		Integrated	To view our large range of accessory parts, please refer to the "Accessories" chapter.