

Brushless DC-Servomotors

2 Pole Technology

3,3 mNm
17 W

Series 1628 ... B

Values at 22°C and nominal voltage		1628 T	012 B	024 B	
1	Nominal voltage	U_N	12	24	V
2	Terminal resistance, phase-phase	R	4,36	15,2	Ω
3	Efficiency, max.	η_{max}	68	69	%
4	No-load speed	n_0	30 800	31 600	min^{-1}
5	No-load current, typ. (with shaft \varnothing 1,5 mm)	I_0	0,087	0,045	A
6	Stall torque	M_H	9,79	11	mNm
7	Friction torque, static	C_0	0,148	0,148	mNm
8	Friction torque, dynamic	C_V	$5,33 \cdot 10^{-6}$	$5,33 \cdot 10^{-6}$	$\text{mNm}/\text{min}^{-1}$
9	Speed constant	k_n	2 645	1 349	min^{-1}/V
10	Back-EMF constant	k_E	0,378	0,741	$\text{mV}/\text{min}^{-1}$
11	Torque constant	k_M	3,61	7,08	mNm/A
12	Current constant	k_I	0,277	0,141	A/mNm
13	Slope of n-M curve	$\Delta n/\Delta M$	3 195	2 896	$\text{min}^{-1}/\text{mNm}$
14	Terminal inductance, phase-phase	L	134	517	μH
15	Mechanical time constant	τ_m	18,1	16,4	ms
16	Rotor inertia	J	0,54	0,54	gcm^2
17	Angular acceleration	α_{max}	181	204	$\cdot 10^3 \text{rad}/\text{s}^2$
18	Thermal resistance	R_{th1} / R_{th2}	5,6 / 22,5		K/W
19	Thermal time constant	τ_{w1} / τ_{w2}	5,7 / 283		s
20	Operating temperature range:				
	– motor		-30 ... +125		$^{\circ}\text{C}$
	– winding, max. permissible		+125		$^{\circ}\text{C}$
21	Shaft bearings		ball bearings, preloaded		
22	Shaft load max.:				
	– with shaft diameter		1,5		mm
	– radial at 3 000 min^{-1} (4 mm from mounting flange)		17		N
	– axial at 3 000 min^{-1} (push only)		10		N
	– axial at standstill (push only)		20		N
23	Shaft play:				
	– radial	\leq	0,015		mm
	– axial	$=$	0		mm
24	Housing material		aluminium, black anodized		
25	Mass		30		g
26	Direction of rotation		electronically reversible		
27	Speed up to	n_{max}	70 000		min^{-1}
28	Number of pole pairs		1		
29	Hall sensors		digital		
30	Magnet material		SmCo		
Rated values for continuous operation					
31	Rated torque	M_N	2,62	2,74	mNm
32	Rated current (thermal limit)	I_N	0,829	0,442	A
33	Rated speed	n_N	19 130	20 540	min^{-1}

Note: Rated values are calculated with nominal voltage and at a 22°C ambient temperature. The R_{th2} value has been reduced by 25%.

Note:

The diagram indicates the recommended speed in relation to the available torque at the output shaft for a given ambient temperature of 22°C.

The diagram shows the motor in a completely insulated as well as thermally coupled condition (R_{th2} 50% reduced).

The nominal voltage (U_N) curve shows the operating point at nominal voltage in the insulated and thermally coupled condition. Any points of operation above the curve at nominal voltage will require a higher operating voltage. Any points below the nominal voltage curve will require less voltage.

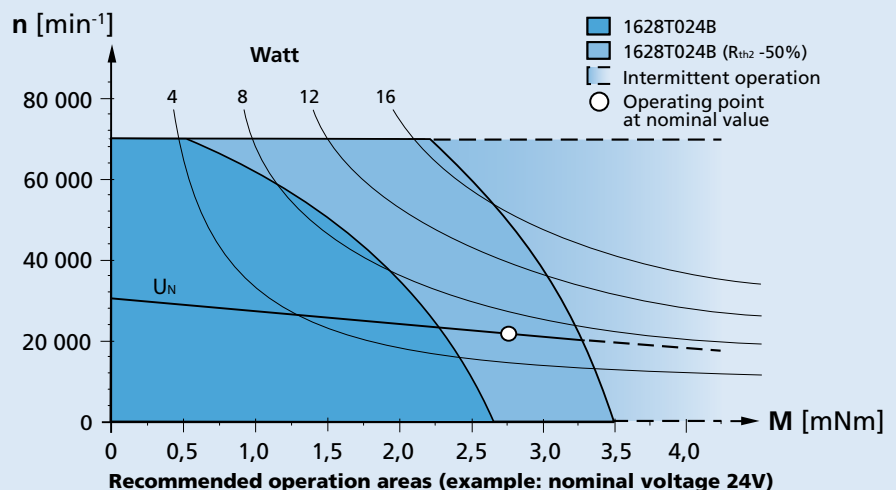

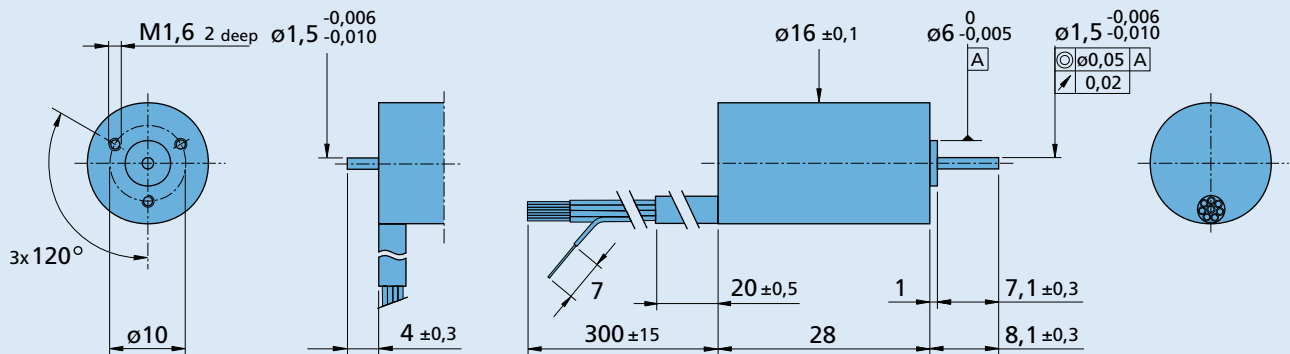
Dimensional drawing

1628 T ... B - K312
1628 T ... B
Option, cable and connection information

 Example product designation: **1628T012B-K1155**

Option	Type	Description	Connection	
			Function	Colour
K1155	Controller combination	Analog Hall sensors for combination with Speed Controller SC and Motion Controller MCBL	Phase C	yellow
K903	Lead wires length	Single lead wires 1000 mm long in PTFE	Phase B	orange
K313	Encoder combination	Motor with rear end shaft for combination with Encoder IE2	Phase A	brown
K312	Encoder combination	Motor with rear end shaft	GND	black
K179	Bearing lubrication	For vacuum of 10^{-5} Pa @ 22°C	U _{DD} (+5V)	red
			Hall sensor C	grey
			Hall sensor B	blue
			Hall sensor A	green
			Standard cable	
			Single wires, material PTFE	
			8 conductors, AWG 26	

Product combination

Precision Gearheads / Lead Screws	Encoders	Drive Electronics	Cables / Accessories
15/10 16/7 17/1	IE2-1024	SC 1801 P SC 1801 S SC 2402 P SC 2804 S MCBL 3002 P MCBL 3002 S MCBL 3003 P MC 5004 P MC 5004 P STO	To view our large range of accessory parts, please refer to the "Accessories" chapter.