

Flat DC-Micromotors

Precious Metal Commutation with integrated Encoder

0,4 mNm
0,8 W

Series 1506 ... SR IE2-8

Values at 22°C and nominal voltage		1506 N	003 SR	006 SR	012 SR	IE2-8
1	Nominal voltage	U_N	3	6	12	V
2	Terminal resistance	R	10,4	50,5	130	Ω
3	Efficiency, max.	η_{max}	68	66	70	%
4	No-load speed	n_0	13 400	14 300	15 500	min ⁻¹
5	No-load current, typ. (with shaft \varnothing 0,8 mm)	I_0	0,01	0,005	0,003	A
6	Stall torque	M_H	0,54	0,46	0,64	mNm
7	Friction torque	M_R	0,02	0,02	0,02	mNm
8	Speed constant	k_n	4 640	2 480	1 340	min ⁻¹ /V
9	Back-EMF constant	k_E	0,216	0,403	0,749	mV/min ⁻¹
10	Torque constant	k_M	2,06	3,84	7,15	mNm/A
11	Current constant	k_I	0,486	0,26	0,14	A/mNm
12	Slope of n-M curve	$\Delta n / \Delta M$	24 700	31 400	24 200	min ⁻¹ /mNm
13	Rotor inductance	L	175	720	2 100	μ H
14	Mechanical time constant	τ_m	24	30	23	ms
15	Rotor inertia	J	0,09	0,09	0,09	gcm ²
16	Angular acceleration	α_{max}	58	50	71	$\cdot 10^3$ rad/s ²
17	Thermal resistance	R_{th1} / R_{th2}	36 / 61			K/W
18	Thermal time constant	τ_{w1} / τ_{w2}	5,4 / 190			s
19	Operating temperature range:					
	– motor		+0 ... +70			°C
	– winding, max. permissible		+70			°C
20	Shaft bearings		sintered bearings			
21	Shaft load max.:					
	– with shaft diameter		0,8			mm
	– radial at 3 000 min ⁻¹ (3 mm from bearing)		0,5			N
	– axial at 3 000 min ⁻¹		0,1			N
	– axial at standstill		10			N
22	Shaft play:					
	– radial	\leq	0,03			mm
	– axial	\leq	0,2			mm
23	Housing material		plastic			
24	Mass		7,1			g
25	Direction of rotation		clockwise, viewed from the front face			
26	Speed up to	n_{max}	16 000			min ⁻¹
27	Number of pole pairs		2			
28	Magnet material		NdFeB			
Rated values for continuous operation						
29	Rated torque	M_N	0,37	0,29	0,4	mNm
30	Rated current (thermal limit)	I_N	0,2	0,086	0,063	A
31	Rated speed	n_N	2 500	2 500	2 530	min ⁻¹

Note: Rated values are calculated with nominal voltage and at a 22°C ambient temperature. The R_{th2} value has been reduced by 0%.

Note:

The diagram indicates the recommended speed in relation to the available torque at the output shaft for a given ambient temperature of 22°C.

The diagram shows the motor in a completely insulated as well as thermally coupled condition (R_{th2} 50% reduced).

The nominal voltage (U_N) curve shows the operating point at nominal voltage in the insulated and thermally coupled condition. Any points of operation above the curve at nominal voltage will require a higher operating voltage. Any points below the nominal voltage curve will require less voltage.

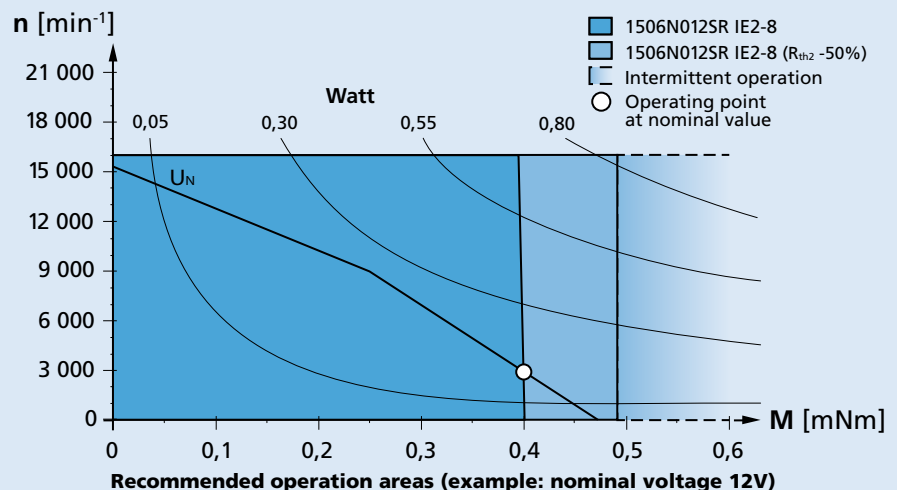

Dimensional drawing

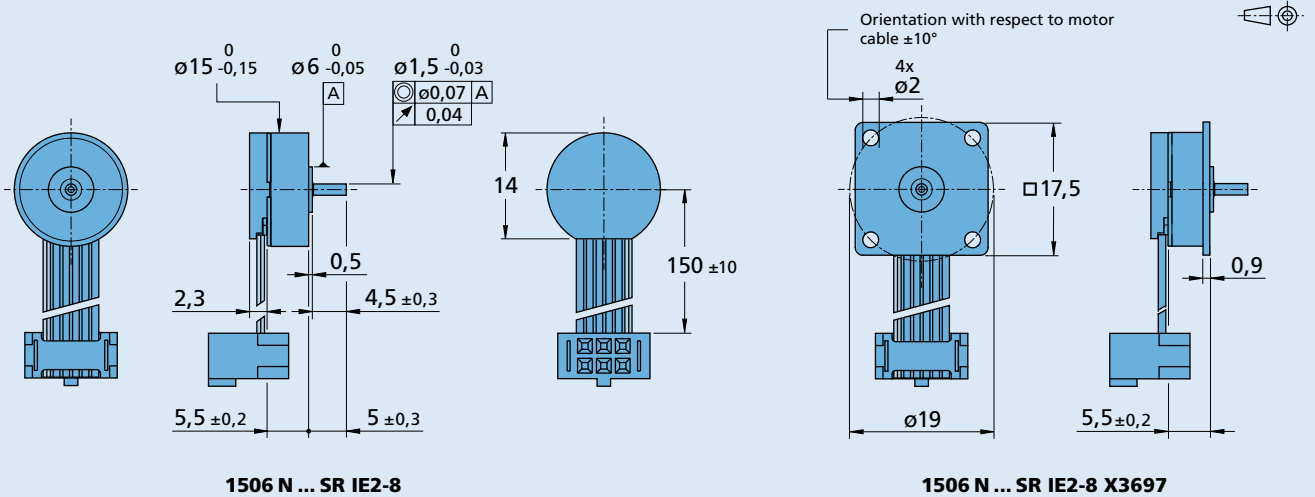

Integrated optical Encoder

	IE2-8		
Lines per revolution	<i>N</i>	8	
Signal output, square wave		2	Channel
Supply voltage	U_{DD}	3,2 ... 5,5	V DC
Current consumption, typical ($U_{DD} = 5V$ DC)	I_{DD}	typ. 8, max. 15	mA
Output current, max. allowable (at $U_{out} < 1,5V$)	I_{OUT}	5	mA
Pulse width ¹⁾	<i>P</i>	180 ± 45	°e
Phase shift, channel A to B ¹⁾	Φ	90 ± 45	°e
Signal rise/fall time, max. ($C_{LOAD} = 50$ pF)	<i>tr/tf</i>	2,5/0,3	µs
Frequency range ²⁾ , up to	<i>f</i>	4,5	kHz

¹⁾ Ambient temperature 22°C (tested at 1kHz)

²⁾ Velocity (min⁻¹) = f (Hz) x 60/N

Features

In this version, the DC-Micromotors have an optical encoder with two output channels. A code wheel on the shaft is optically captured and further processed. At the encoder outputs, two 90° phase-shifted rectangular signals are available with 8 impulses per motor revolution.

The encoder is suitable for the monitoring and regulation of the speed and direction of rotation and for positioning the drive shaft.

The supply voltage for the encoder and the DC-Micromotor as well as the two channel output signals are interfaced through a ribbon cable with connector.

Full product description

■ Examples:

1506N003SR IE2-8

1506N012SR IE2-8

Output signals / Circuit diagram / Connector information

Output signals

with clockwise rotation as seen from the shaft end

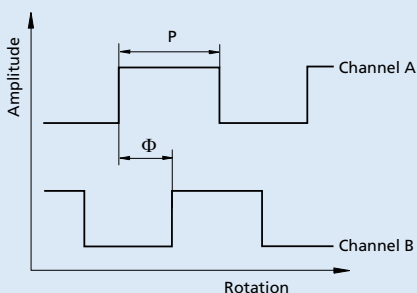

Admissible deviation of phase shift:

$$\Delta\Phi = \left| 90^\circ - \frac{\Phi}{P} * 180^\circ \right| \leq 45^\circ$$

Output circuit

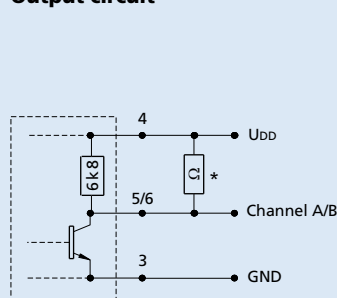

* An additional external pull-up resistor can be added to improve the rise time. Caution: I_{OUT} max. 5 mA must not be exceeded!

Pin Function

- 1 Motor -
- 2 Motor +
- 3 GND
- 4 U_{DD}
- 5 Kanal B
- 6 Kanal A

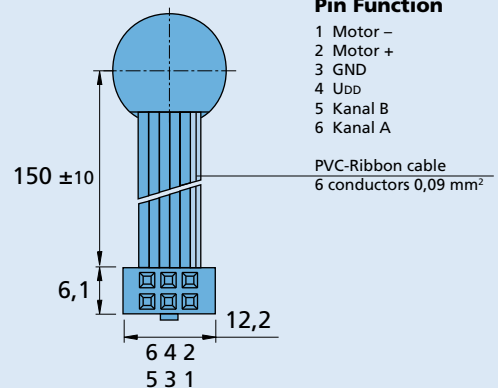

Connector
DIN-41651
grid 2,54 mm