

UK Operating Instructions

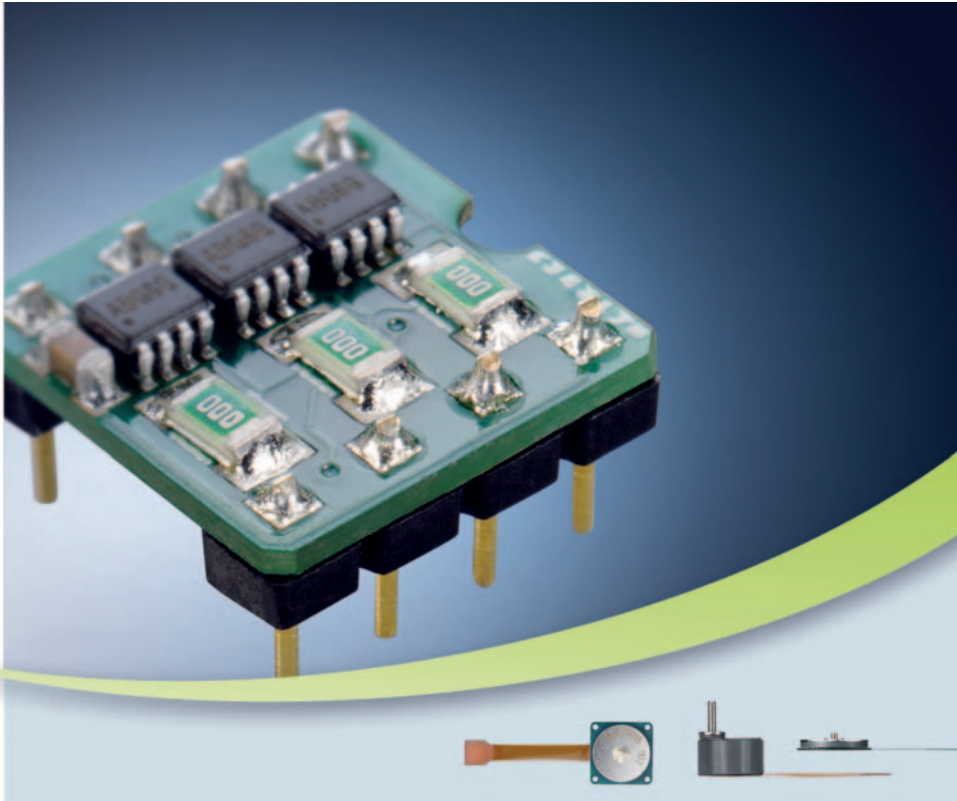

Table of Contents

1 Description	4
2 General information on the operation of synchronous motors	4
3 Dimensions and pin assignment	5
4 Power supply	7
5 Adjusting the motor voltage	7
6 Operation with continuous movement (synchronous motor)	8
7 Incremental positioning mode (stepping motor)	8

1 Description

The BLD 05002 S is an electronic control for synchronous micro-motors.

- Due to the external commutation, the exact speed can be preset via a digital clock signal.
- The amplitude of the phase voltages can be adjusted via an analog input (cf. Chap. 5 *Adjusting the motor voltage*).
- Operation is possible as a stepper motor in microstepping mode.
- The circuit is designed as a plug-in hybrid module for a DIL8 socket.

2 General information on the operation of synchronous motors

- Synchronous motors must be accelerated to the desired speed via an acceleration ramp. The load moment including acceleration moment must never exceed the maximum motor torque. Otherwise, the motor may stop and generally does not automatically restart.
- Synchronous motors are prone to oscillating movements, with a resonance frequency dependent on the load and motor current, which cannot be universally specified. To ensure faultless operation, this frequency should not be excited either by the load or the stepping frequency.

3 Dimensions and pin assignment

Dimensions

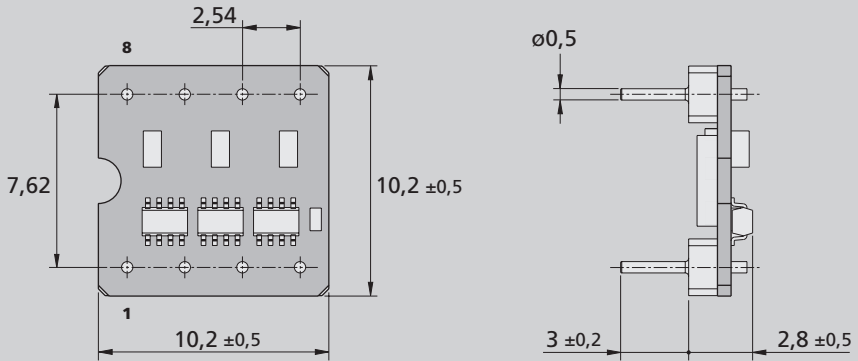

Pin assignment

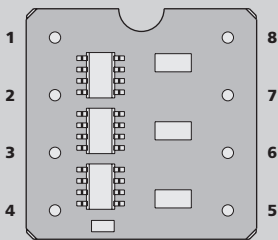

Pin	Terminal
1	U_m
2	Clk
3	Dir
4	GND
5	Phase A
6	Phase B
7	Phase C
8	U_{cc}

3 Dimensions and pin assignment

Pin		Description
U_m	Analog input	$U_m > U_{cc}/2$: Amplitude preset of phase voltages $U_m < 0.8 U$: Motor deactivated
Clk	Digital clock input	At each rising edge the motor is rotated by one micro-step
Dir	Digital input	Presetting of direction of rotation
GND	Reference potential	
Phase A, Phase B, Phase C,	PWM output	Connections of the three phases of the synchronous micro-motor
U_{cc}	Supply voltage	Permissible voltage range: 2,7 V... 5,5 V Maximum power consumption including motor: around 300 mA

4 Power supply

- Operating voltage range: 2,7 V to 5,5 V stabilised, no polarity reversal protection
- Power consumption with motor switched off: around 5 mA
- Maximum permissible output current: 250 mA

5 Adjusting the motor voltage

The motor voltage is set by an analogue control voltage at analogue input "U_m". It is calculated from the supply voltage U_{cc} and the voltage at U_m as follows:

$$U_{\text{motor}} = (U_m - U_{cc}/2) \cdot 0,707$$

A practical range for U_m is U_{cc}/2 to U_{cc}.

6 Operation with continuous movement (synchronous motor)

The speed is set by means of an external clock signal at digital input "Clk". It is calculated from the number of pole pairs p and the clock frequency f_{clk} as follows:

$$n = f_{\text{clk}} / (48 \cdot p)$$

The motor's direction of rotation can be reversed with digital input "Dir".

A clock frequency of 10 kHz for instance results in a speed of 3 125 rpm on the penny-motor.

7 Incremental positioning mode (stepping motor)

At each rising edge of the clock signal at pin "Clk", the quiescent position of the rotor is moved one micro-step in the direction preset by the level present at pin "Dir". In this way it is possible to move specifically to a desired position. The micro step width $\Delta\varphi$ and the number of steps per revolution N depend on the number of pole pairs p of the connected motor.

They can be calculated as follows:

$$\Delta\varphi = 360^\circ / (48 \cdot p)$$

$$N = 48 \cdot p$$

If a position is to be retained at rest, then the motor current should remain switched on, as the synchronous motors do not present any latching moment in de-energised state.

The rotor is "sprung" into its quiescent position by the magnetic field. The actual position may deviate slightly, depending on load moment and motor current.

Motor	No. of pole pairs	$\Delta\varphi$	N
0206,0308,0513	1	7,5°	48
1202,1307,1309	4	1,875°	192

mymotors & actuators GmbH
Mikroforum Ring 3
55234 Wendelsheim · Germany
Phone +49 (0)67 34 / 91 19-10
Fax +49 (0)67 34 / 91 19-11
Email: info@mymotors.de

Sales:

**DR. FRITZ FAULHABER
GMBH & CO. KG**

Daimlerstraße 23
71101 Schönaich · Germany
Phone +49 (0)70 31 / 638-0
Fax +49 (0)70 31 / 638-100
Email: info@faulhaber.de

MicroMo Electronics, Inc.

14881 Evergreen Avenue
Clearwater · FL 33762-3008 · USA
Phone: +1(727) 572-0131
Fax: +1(727) 573-5918
Toll-Free: (800) 807-9166
Email: info@micromo.com



www.faulhaber-group.com/mymotors



More information? Go online!

Feel free to browse through the latest product highlights, inspirational application reports, interesting press information and order our catalogues and documentations easily and conveniently at the click of a mouse button.

